

TECHNICAL INFORMATION

Powerful Wetting NO CLEAN SOLDER PASTE

SE48-M1000-3

SS48-M1000-3

[Contents]

1. FEATURES	Page 2
2. SPECIFICATIONS	2
3. TEMPERATURE - VISCOSITY CURVE	3
4. VISCOSITY VARIATION	4
5. TACK FORCE	5
6. SLUMP	6
7. SOLDER BALLING	8
8. SPREAD FACTOR & WETTING	10
9. COPPER PLATE CORROSION	13
10. SURFACE INSULATION RESISTANCE	14
11. VOLTAGE APPLIED SIR	15
12. USE OF KOKI SOLDER PASTE	16

1. FEATURES

- 1) Employment of rigidly classified 20~45 micron solder powder ensures outstanding continual printing with fine pitch (0.5mm/20mil) and even super fine pitch (0.4mm/16mil) applications and exhibits long stencil idle time.
- 2) Carefully selected rosins and activators ensure powerful solder wetting.
- 3) Extremely long stencil idle time and tack time offer wide process window.
- 4) Low colour flux residue offers superior cosmetic appearance.
- 5) Conforms to Bellcore tests (Copper mirror, Halides, Surface insulation resistance, Electromigration) GR-78-CORE, Issue 1.

2. SPECIFICATIONS

1) Alloy

Item	Unit	SE48-M1000-3	SS48-M1000-3	Remarks
Composition	%	Sn63, Pb37	Sn62, Pb36, Ag2	JIS E grade
Shape	--	Spherical		Microscope×50
Particle size	μm	20 ~ 45		

2) Flux

Halogen content	%	0.0	Potentiometer
SIR* ¹	Initial value	$> 1 \times 10^{13}$	JIS comb type electrode type II
	After humidification	$> 1 \times 10^{11}$	
Aqueous solution resistivity* ²	Ωcm	$> 2 \times 10^4$	Conductivity
Flux type	-	ROL0	ANSI/J-STD-004

3) Solder paste

Flux content	%	10	By weight
Viscosity* ³	Ps	1900 ± 10%	Malcom PCU-2
Copper plate corrosion* ⁴	--	Passed	--
Solder spread factor	%	90	Copper plate
Tack time	hour	> 24	Malcom FG-1
Shelf life	month	6	Below 10°C

1. SIR 40°C×90%RH×96Hr
2. Aqueous solution resistivity..... In accordance with MIL specifications.
3. Viscosity Malcom spiral type viscometer, PCU-2 at 25°C 10rpm
4. Copper plate corrosion In accordance with JIS

3. TEMPERATURE - VISCOSITY CURVE

• Test method

Equipment : Malcom viscometer PCU-205

Rotation of spindle : 10 r.p.m.

Measuring time : 5 min,

• Test result

Measuring temp. (°C)	Viscosity (Ps)
20	2280
25	1927
30	1385

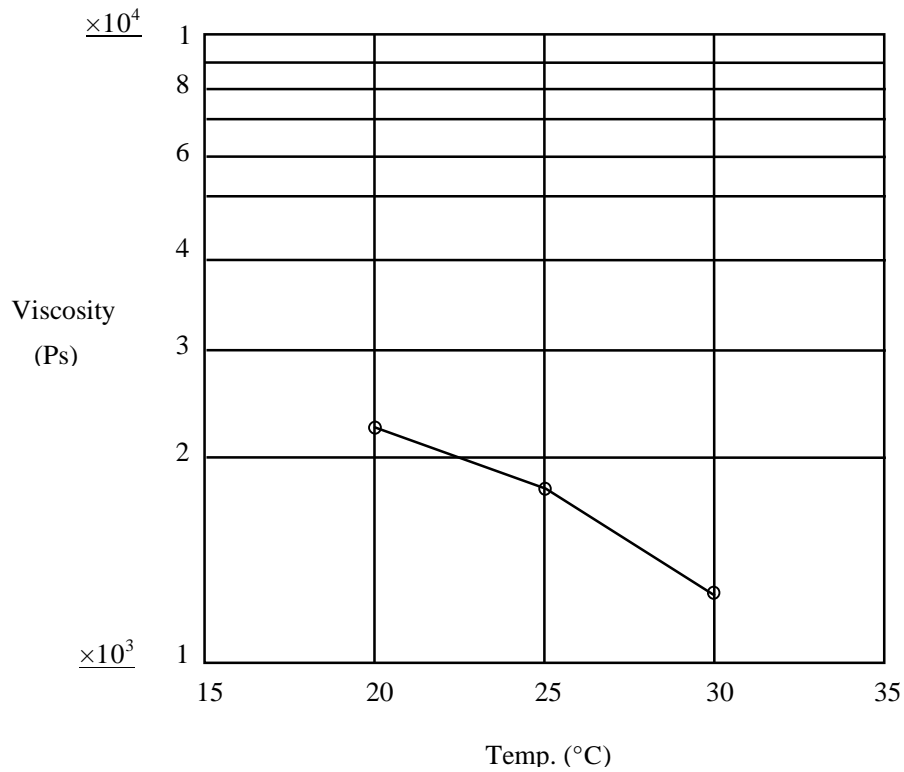

4. Viscosity Variation during Continual Print

- Test method

Print (knead) solder paste on the sealed-up stencil continuously for up to 4 hours to observe viscosity variation.

Stencil : 0.15mm thickness, laser cut stencil
 Printer : Model MK-880SV Minami Kogaku
 Squeegee : Metal blade
 Angle - 60°
 Speed - 30 mm/sec

Print stroke : 300mm
 Atmosphere : 23.5~25.0°C 50~60%RH

Measurement of viscosity : Before printing, at 1, 2, 3 and 4 hours by Malcom viscometer PCU-205

- Result

Time (hour)	Initial	After kneading for 3 min.	1	2	3	4
Viscosity (Ps)	1923	1593	1651	1684	1720	1722

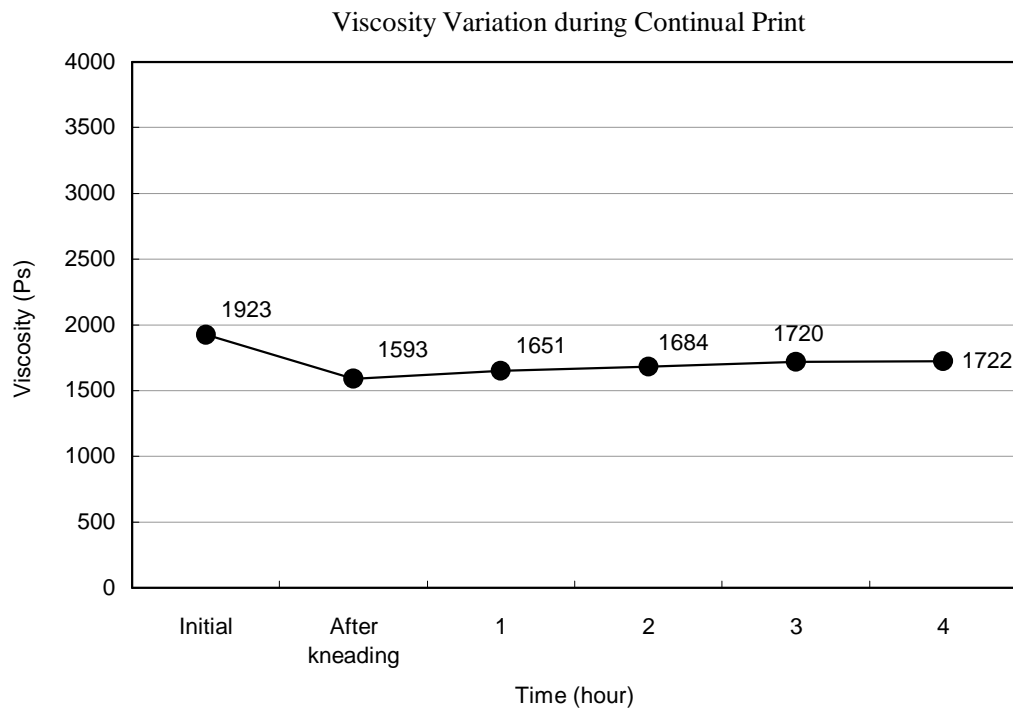

5. TACK FORCE

- Test method

Print the solder paste on an alumina plate with a 0.2mm thick stencil that has five 6.5mm dia. holes, to obtain the test piece.

Press the flat tip of the cylindrical probe of the Malcom Solder Checker FG-1 onto the printed solder paste with a pressure of 50gs for 0.2mm sec. and pull it back up at a speed of 10mm/sec. to measure the maximum tensile strength needed to separate the probe from the paste.

Evaluate tackiness of the solder paste from the obtained tack force and time after printing.

*Ambient condition : 25°C 50±10%RH

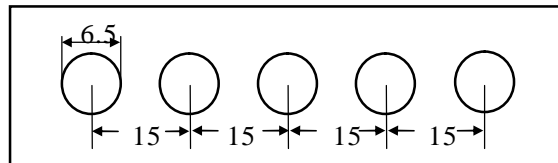

*Unit : mm

Stencil used

Product	Time (hour)						
	0	2	4	6	8	16	24
Tackiness (gf)	151	154	150	149	149	138	120

*Unit : (gf) Average of n = 5

Tackiness Data

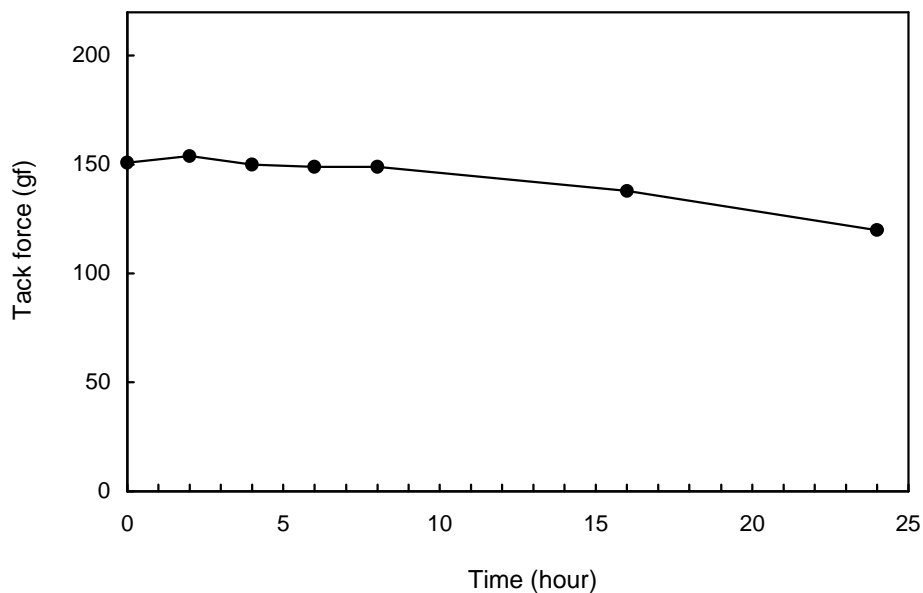

6. SLUMP

• Test method

Using a 0.2mm thick stainless steel stencil with two patterns of apertures, (1)3.0mm×0.7mm, (2)3.0mm×1.5mm arranged as grids with the spacing between the apertures varying from 0.2mm to 1.2mm in steps of 0.1mm, print the solder paste on a 1.6mm thick copper clad laminate plate to obtain the test pieces.

- (1) Observe the slump behaviour after leaving the test pieces at room temperature for 1 hour.
- (2) Observe the minimum spacing across which the paste has not merged after storing the test pieces at room temperature for 1 hour, and heating it for 5 minutes at 150°C in the thermostatic oven.

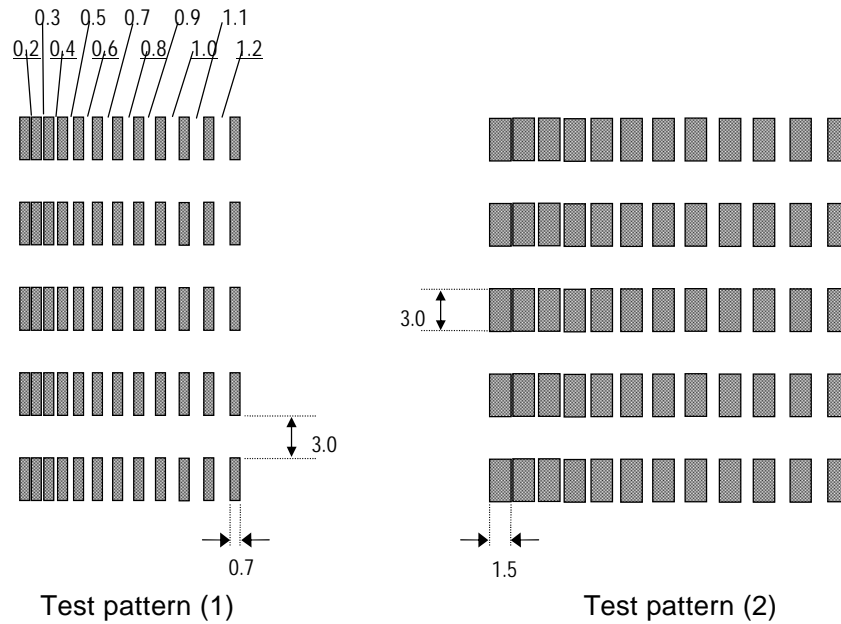

• Test result

n	Stored at room temperature for 1 hour		
	Room temp.	100°C×20min.	150°C×5min.
(1)	0.2	0.2	0.3
(2)	0.2	0.2	0.3

*Store at room temperature for 1 hour.

Room temperature (no heating)

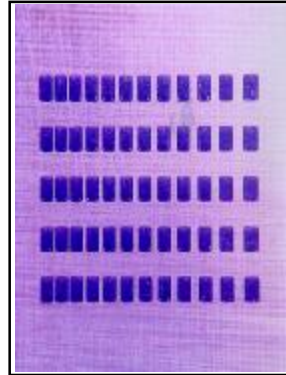
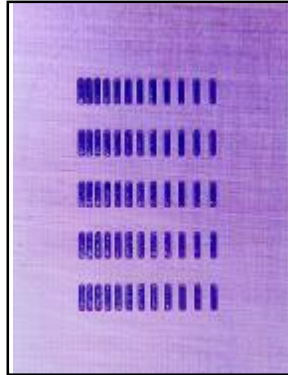

100°C × 20min.

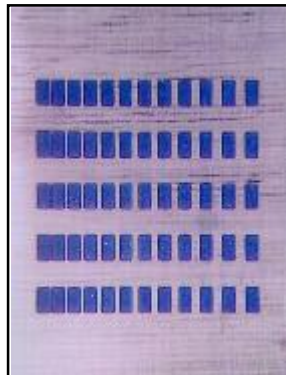
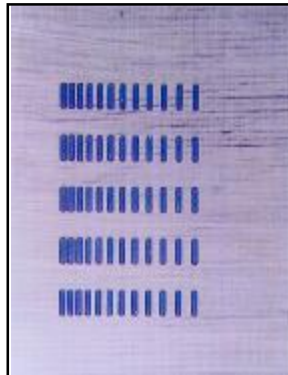

150°C × 5min.

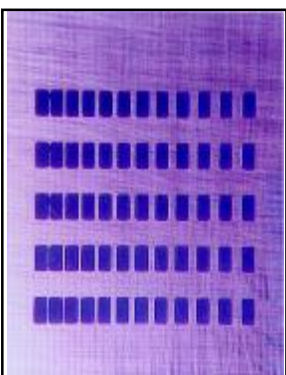
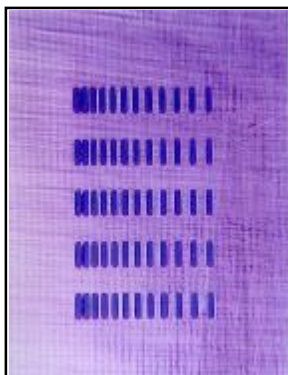

7. SOLDER BALLING

- Test method

Prepare two test pieces by printing the paste on each alumina plate (50×50×0.8mm) with a 0.2mm thick stencil provided with three 6.5mm diameter apertures with a distance between centres of 15mm.

Reflow one of them 1 hour after printing and the other after storing it at 25±2°C 60±20%RH for 24 hours, on a hot plate at 250°C. Remove the test pieces from the hot plate after 5 seconds once the solder paste has melted completely and cool them down to room temperature.

Inspect the degree of reflow referring to the 'Solder balling evaluation standard' using a ×10 magnifying glass.

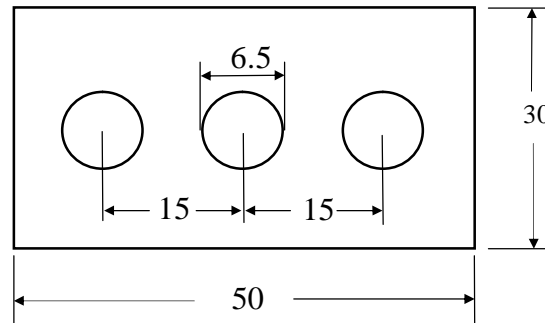

Unit : mm

Stencil used.

- Solder balling evaluation standard

Category	Status of coalescence of solder	Illustration (ex.)
1	The molten solder from the paste has melted into one solder ball.	
2	The molten solder from the paste has melted into one large solder ball with no more than three isolated small solder balls with a diameter less than 75µm.	
3	The molten solder from the paste has melted into one large solder ball surrounded by more than three solder balls with diameters less than 75µm which do not form a semi-continuous halo.	
4	The molten solder from the paste has melted into one ball accompanied by a large number of smaller solder balls which may form a semi-continuous halo, or has melted to form a number of similarly sized balls.	

• Test result :

Test piece	1 hour after print	24 hours after print
a	Category 2	Category 3
b	2	2
c	2	3

1 hour after printing



24 hour after printing



8. SOLDER SPREAD FACTOR & WETTING

• Test method

1. Test board

Model : SP-RTP-002
 Material : Glass epoxy FR-4
 Dimension : 80×100×1.6mm
 Surface treatment : Bare copper
 Pad size (round pad) : 6.0mm

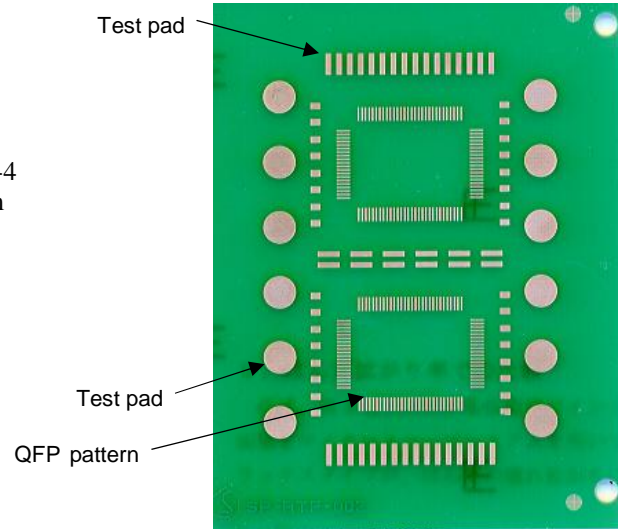

2. QFP tested

PC board : Glass epoxy FR-4
 Component : QFP 0.65mm pitch 100 pins
 Lead wire : Ni/Fe with Sn/Pb plating

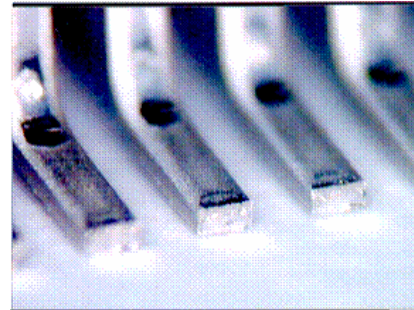

3. Print condition

Stencil thickness : 0.150mm (laser cut)
 Printer : Model MK-880SV (Minami Kogaku)

4. Reflow condition

Heat source : Far infrared + Hot air convection
 Zone structure : 3 pre-heat zones + 1 reflow zone
 Atmosphere : Air
 Temperature profile :

Profile	Pre-heat zones	Peak temp.	Time over 220°C
Profile	150 - 160°C × 90 sec.	220°C	40sec.

- Result

Solder spread results

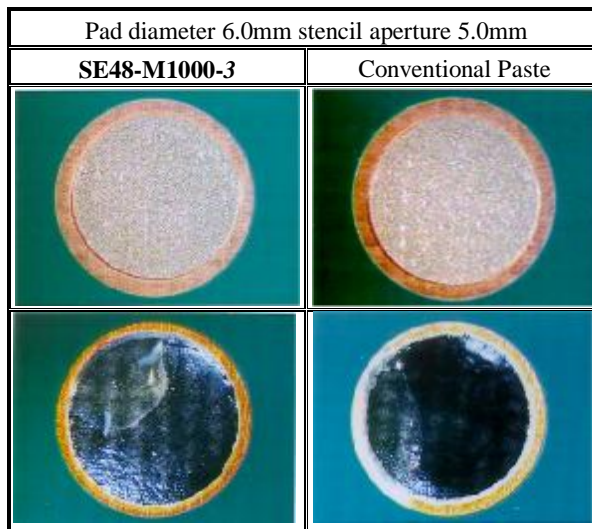
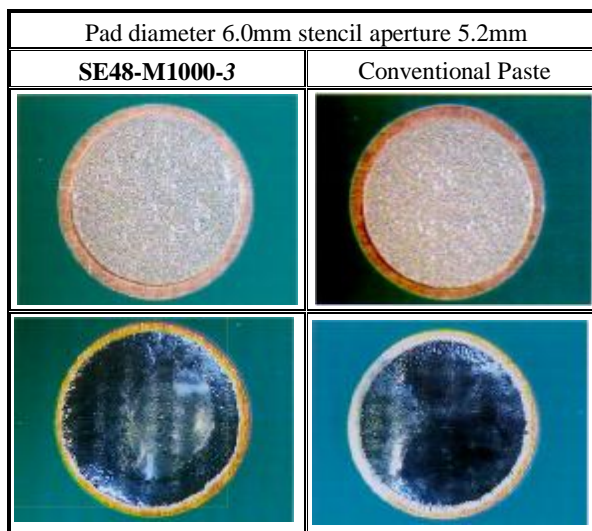
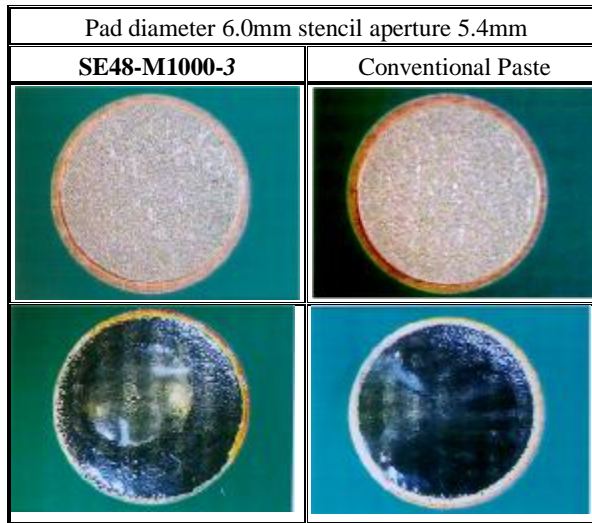

Solder wetting results

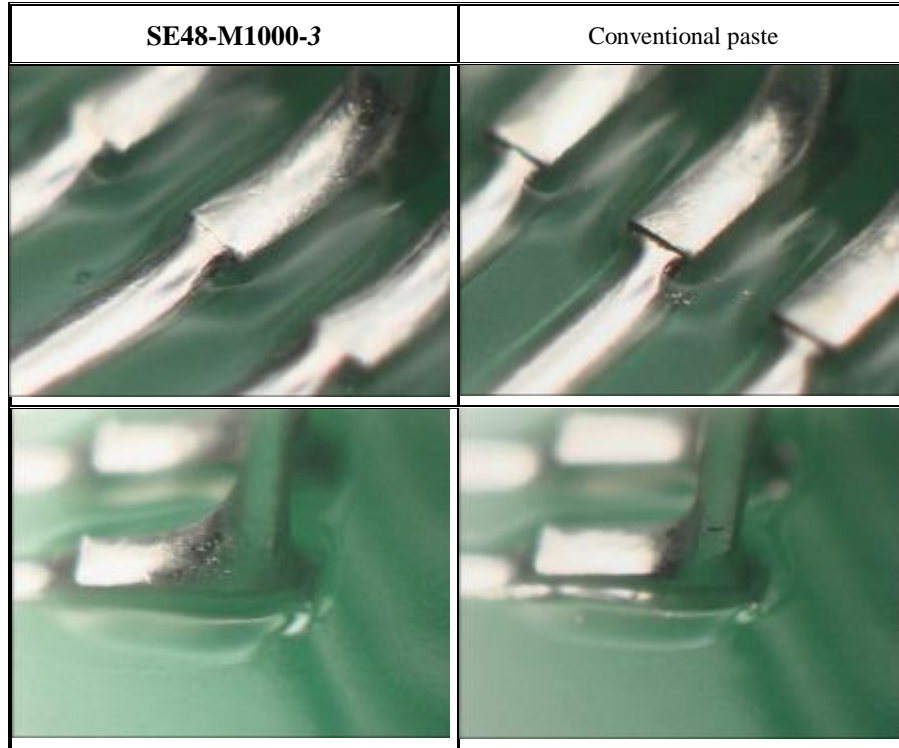

9. COPPER PLATE CORROSION

• Test method

Prepare 6 pcs. of phosphorus deoxidized copper plate of 50×50×0.5t mm in size (JIS-H-3100). Bend 3 of them at right angles at 5mm (copper plate A), and the rest at 6mm (copper plate B) from both edges to form three open ended boxes.

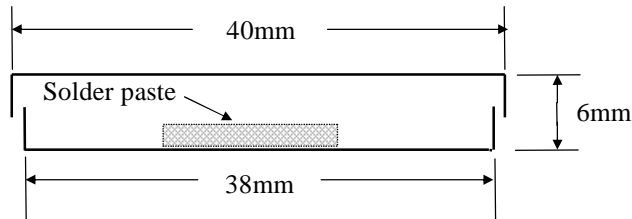

After removing grease from both copper plate A and B with acetone, soak them in 5% sulfuric acid for 1 minute and in ammonium persulfate solution (solution which contains 25% of ammonium persulfate in 0.5% of sulfuric acid) for 1 minute to etch the surface uniformly. After washing them with running water, soak in 5% sulfuric acid for 1 minute and rinse thoroughly with running tap water and demineralised water. Then finally, rinse them with acetone and dry.

Obtain the test pieces by printing solder paste on the copper plate B with a 0.2mm thick stencil provided with a 6.5mm diameter aperture.

Place all three copper plates A over the copper plates B and lower each box in a horizontal position onto the surface of the solder bath at a temperature of $235\pm 2^{\circ}\text{C}$ and maintain the test pieces in this position for 5 seconds.

Remove each test piece from the solder bath and allow it to cool in a horizontal position down to room temperature. Place all three boxes in the thermohygrostat under the condition of $40\pm 2^{\circ}\text{C}$, 90~95%RH for 72 hours.

Remove the boxes from the thermohygrostat and inspect the inside surfaces of the boxes (including the lid) for possible corrosion.

• Test result

n	Copper plate A	Copper plate B
1	No corrosion	No corrosion
2	No corrosion	No corrosion
3	No corrosion	No corrosion

10. SURFACE INSULATION RESISTANCE

- Print the solder paste with a 0.2mm thick stencil on comb type electrode type-II specified in JIS-Z-3197: 1999 8.5.3 and reflow them to obtain the test piece.

Put the test piece in a thermohygrostat under the conditions of $85\pm 2^{\circ}\text{C}$ and $85\pm 2\% \text{RH}$.

Measure the insulation resistance at every specific time taking the test pieces out of the thermohygrostat. DC100V for the measurement.

- Test result

Time (hour)	S.I.R. Value (Ω)
Initial value	3.5×10^{14}
96	1.8×10^{12}
168	2.0×10^{12}
336	3.0×10^{12}
504	3.2×10^{12}
1008	3.8×10^{12}

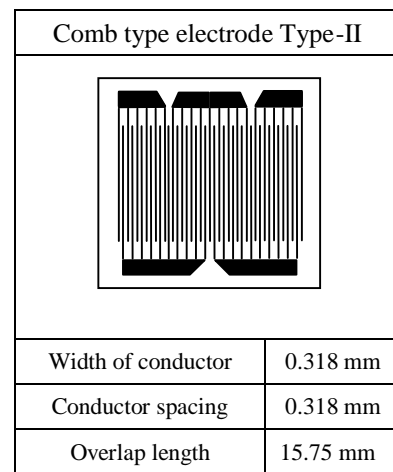

SIR GRAPH

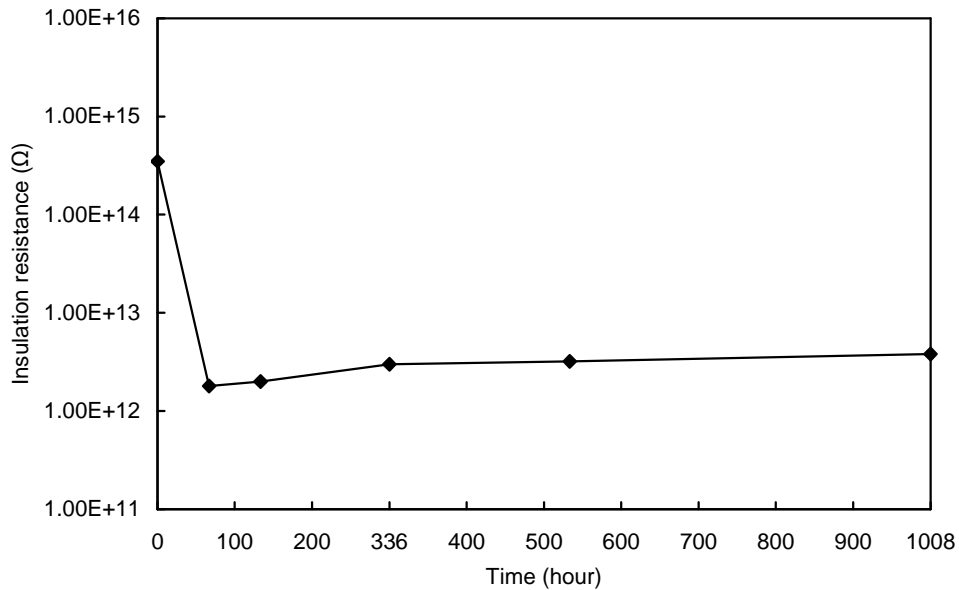

11. VOLTAGE APPLIED SIR (Electromigration Test)

• Test method

Print the solder paste with a 0.2mm thick stencil on comb type electrode Type-II specified in JIS-Z-3197: 1999 8.5.4 and reflow them to obtain the test pieces.

Put the test pieces in a thermohygrostat under the conditions of $85\pm 2^{\circ}\text{C}$ and $85\pm 2\% \text{RH}$.

Measure the insulation resistance at every specific time keeping the test pieces in the thermohygrostat and apply DC50V. Apply 100V for the measurement.

• Test result

Time (hour)	Place measured	Average (Ω)
Initial value	Out thermohygrostat	3.0×10^{14}
96	In thermohygrostat	4.5×10^9
168	In thermohygrostat	1.0×10^{10}
336	In thermohygrostat	2.0×10^{10}
504	In thermohygrostat	2.6×10^{10}
1008	In thermohygrostat	3.5×10^{10}

2 There was no evidence of electromigration.

SIR GRAPH

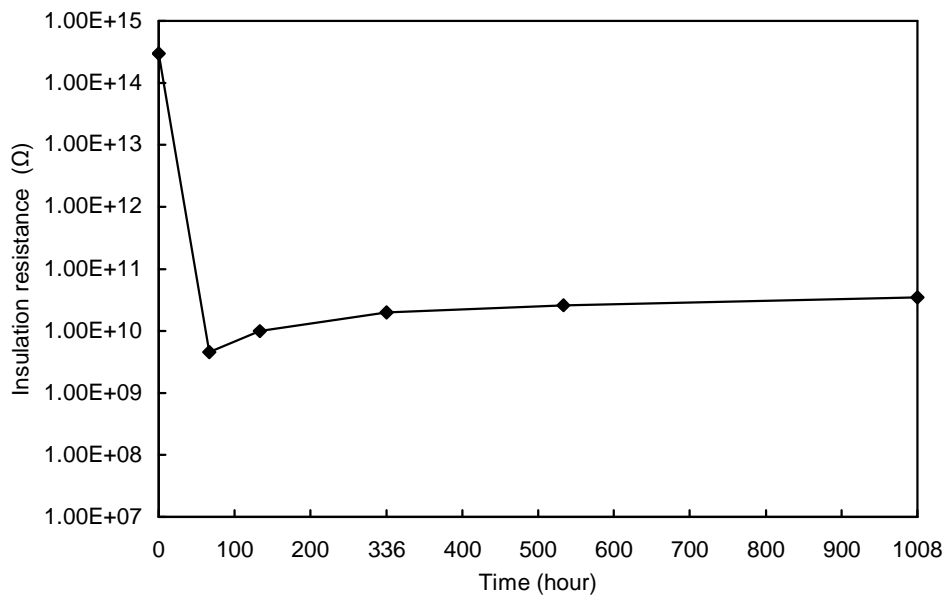

12. USE OF KOKI SOLDER PASTE

In order to optimise the use of KOKI SOLDER PASTE, please refer to the following guidelines carefully before use.

1. Preparation for printing

1) Temperature

After taking the solder paste from the refrigerator, in which the temperature is controlled to between 5 - 10°C, allow the paste temperature to return to ambient.

*Caution : Do not open the jar while it is cold, as it causes condensation moisture on the paste, and could be the cause of poor performance, such as an increase in viscosity, solder balling etc.

Do not under any circumstances heat the paste prior to use.

2) Stirring

By using a stainless steel or chemically resistive plastic spatula, fold the paste before use.

It is recommended to fold it for at least 1~2 min. to obtain a uniform and stable viscosity.

*Caution : When automatic stirring equipment is used, do not stir the paste for longer than 4 min.

2. Printing

1) Recommended printing parameters

(1) Squeegee

1. Kind : Flat
2. Material : Rubber or metal blade
3. Angle : 80~90°(rubber) or metal blade
4. Pressure : Lowest.
5. Squeegee speed : 10~100mm/sec.

(2) Stencil

1. Thickness : 200~120µm for 0.65~0.4mm pitch pattern
2. Snap-off distance : 0~0.5mm

*Although on-contact (0mm snap-off) is normally recommended for fine pitch printing, if the printing equipment is not provided with a stencil separation speed control system, proper snap-off distance is necessary to ensure smooth and gradual separation of the stencil from the substrate to ensure good solder paste deposits.

3. Fixing method of substrate : It is recommended to have a fixture or vacuum system to hold the substrate in position during printing to prevent movement of the PC board and to have a good separation from the stencil.

4. It is strongly recommended to set the stencil separation speed as slow as possible.

(3) Ambient

1. Temperature : $25 \pm 5^{\circ}\text{C}$
2. Humidity : 40~60%RH
3. Climate control : Air flow seriously affects stencil life and tack performance of solder pastes.

*Caution : When local air conditioner is equipped, make sure it is not enhancing the drying out of the solder paste.

